

Project:

Item Number:

Quantity:

3-WELL RETHERMALIZER



DESCRIPTION

With three independently controlled wells, this powerful rethermalizer quickly heats a variety of cold prepared foods and holds each item at proper serving temperatures to maximize food quality and safety and minimize waste. Serving as an extra hand in your commercial kitchen, it can rethermalize or hold three different menu items at different temperature settings, all in the footprint of one unit. Impressive heating and simple controls make it ideal for any professional foodservice operation, providing an easy, energy-efficient way to rethermalize soups, sides, sauces, pasta, beef, poultry and more without the guesswork.

AGENCY LISTINGS



WARRANTY

The Vollrath Company LLC warrants to the original commercial end user that each of Vollrath's foodservice products will be free from defects in materials and workmanship.

For warranty period, exclusions, and details, visit vollrathfoodservice.com/vollrath-resources/warranty-info/warranty-policy.

ITEMS

Item	Model	Description	Max Pan Size Per Well
72033	33W-120	3-Well Rethermalizer, 120V, NEMA 5-15 Plug	Third-size, 6" deep

FEATURES & BENEFITS

- Each of the three 6" deep wells can accommodate third-size and sixth-size pans.
- Independent thermostatic controls for each well provide maximum flexibility—rethermalize chilled food in one while holding hot food in others!
- Meets NSF4 Performance Requirements for rethermalization and hot-food-holding equipment.
- 10 temperature settings, from approximately 104 °F (40 °C)–212 °F (100 °C), allows for precise heat regulation.
- Separate add-water indicators for each well eliminates guesswork.
- Front-access dials simplifies operation.
- Efficiently designed thermostats provide heat only when needed.
- Non-skid feet help prevent slippage on countertops.
- Constructed with high-quality stainless steel, the wells and exterior are not only durable, but easy to clean.
- Made in the U.S.A.
- 6' cord allows placement options.

PERFORMANCE CRITERIA

Countertop Rethermalizers are designed to take a container of cooked food from a chilled state (below 40.0 °F [4.4 °C]) through the HACCP "danger zone" (165 °F [73.9 °C]) in less than 120 minutes. This performance standard is measured using the NSF mixture chilled at 38 °F (3.3 °C). The electric unit then raises the temperature of the product above 165 °F (73.9 °C) in less than 120 minutes. When using a standard pan or insert, with cover, and stirring regularly, the food product temperature can be maintained above 150 °F (65.6 °C).

3-WELL RETHERMALIZER

DIMENSIONS Shown in inches (cm)

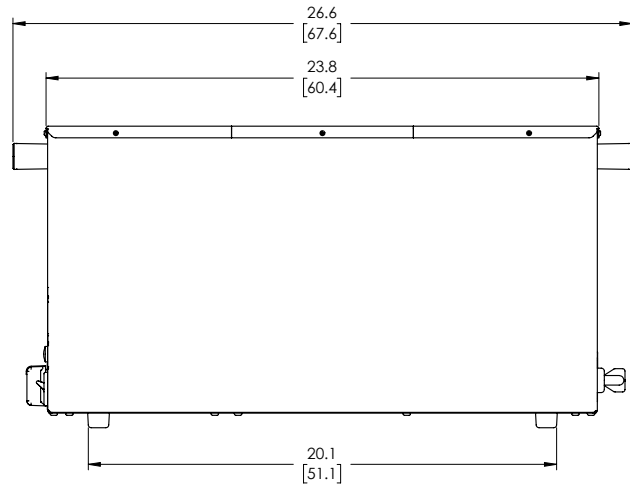
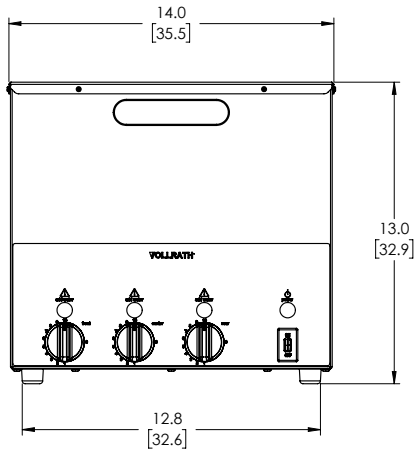
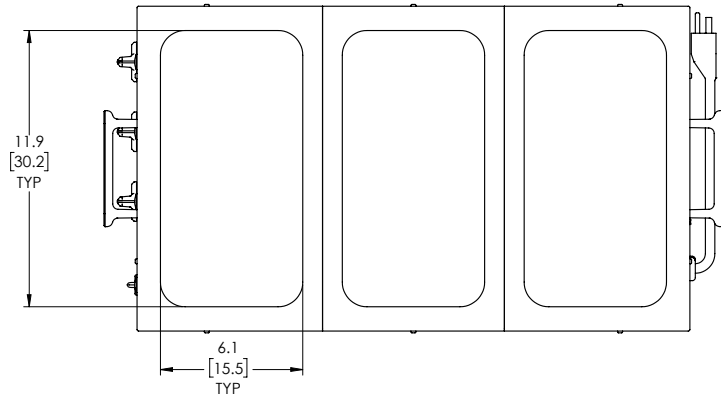

SPECIFICATIONS

Item	Model	Overall Dimensions IN (cm)	Weight LB (Kg)	Shipping Information		Wattage	Amps	Voltage	Plug
				Dimensions IN (cm)	Weight LB (Kg)				
72033	33W-120	14.0W x 26.6D x 13.0H (35.5 x 67.6 x 32.9)	40 (18.1)	18.25W x 30.0D x 15.63H (46.4 x 76.2 x 39.7)	45.0 (20.4)	1200 total 400 per well	10.0 total 3.3 per well	120	NEMA 5-15P 



vollrathfoodservice.com

The Vollrath Company, L.L.C.
 1236 North 18th Street
 Sheboygan, WI 53081-3201 U.S.A.
 Main Tel: 800.624.2051 or 920.457.4851
 Main Fax: 800.752.5620 or 920.459.6573
 Customer Service: 800.628.0830
 Canada Customer Service: 800.695.8560
 © 2026 The Vollrath Company L.L.C.

Technical Services
 techservicereps@vollrathco.com
 Induction Products: 800.825.6036
 Countertop Warming Products: 800.354.1970
 All Other Products: 800.628.0832